

LIM-032-#

PYROMID® multi channel pyroelectric detector

Description:

dual channel; TO39 housing; small chip size; beamsplitter;
JFET; voltage mode;



Housing:

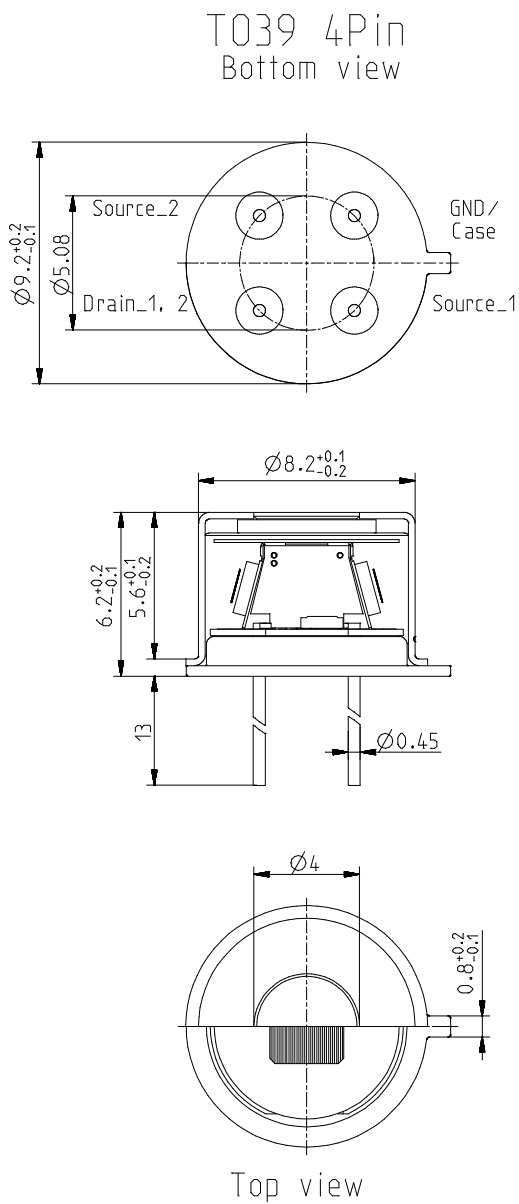

Pin Assigment:

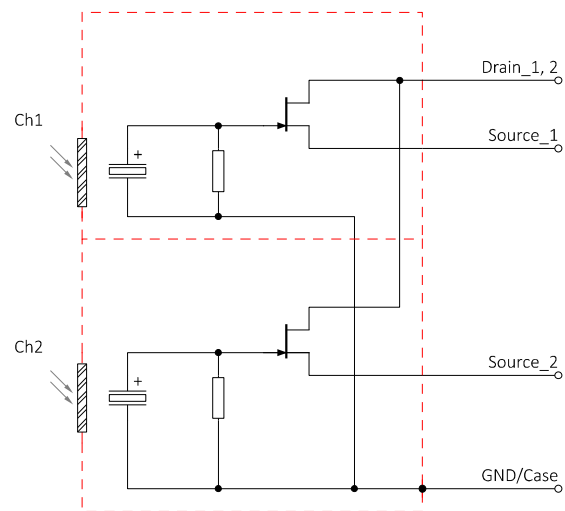

Maximum current between Case and the "Case"-Pin 10 mA!

Frequency Response:

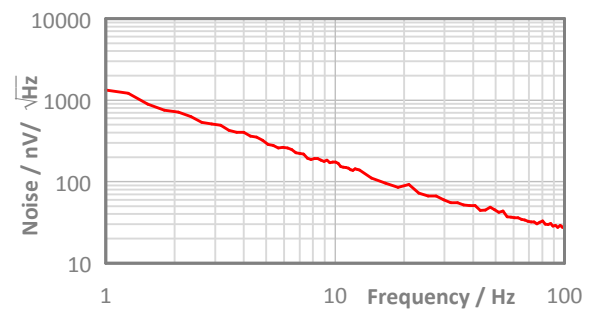
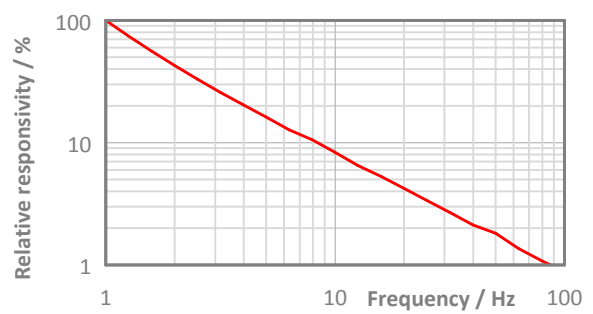

LIM-032-#

PYROMID® multi channel pyroelectric detector

Test Circuit:

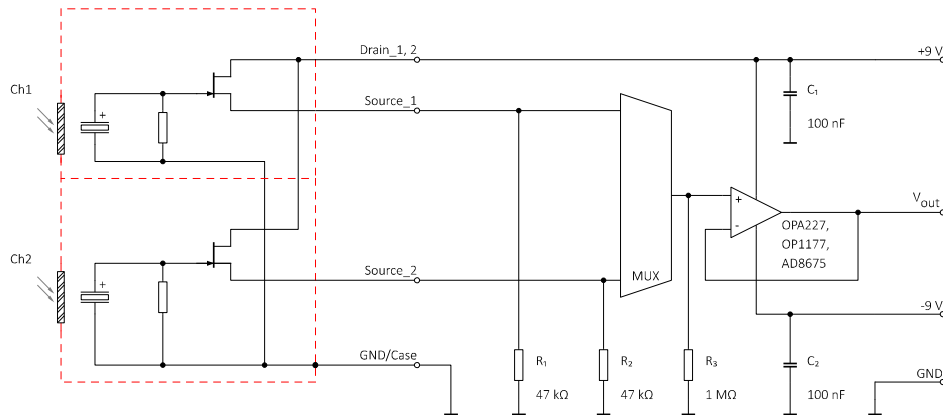

Parameters:

Aperture size	nom	□ 2.8 mm (inlet aperture \varnothing 4.0 mm)
Element size / type	nom	2.2 × 1.3 mm ² lithium-tantalate with black layer
Beamsplitter	nom	Array of micro grooves
Thermal time constant	typ	250 ms
Electrical time constant	typ	5 s
Polarity	nom	Positive signal by positive IR flux change
Voltage responsivity (rms) {500 K, 10 Hz, 25 °C, without filter/window}	min	150 V/W
Noise density (rms) {10 Hz, BW 1 Hz, 25 °C}	max	220 nV/√Hz
Detectivity {500 K, 10 Hz, 1 Hz, 25 °C, without filter/window}	typ	2.9E+08 cmVHz/W
Offset voltage {opt. Drain current = 10 ... 100 μ A}	nom	0.4 ... 1.5 V
Drain source voltage	max	18 V
Operating / Storage temperature	nom	-40 ... +85 °C
IR filter		Combinations of all InfraTec standard narrow band pass filters are available. Customized filters upon request.
Filter sizes	nom	Rectangular filters: (2.70 +0/-0.1 × 2.00 +0.05/-0.1) mm Circular filters: not applicable Standard thickness: 0.50 mm +0.2/-0.1 mm
Aperture window		Selected by manufacturer for best channel filter matching
Aperture window sizes	nom	Rectangular filters: (5.25 × 5.25) mm +0/-0.05 mm Circular filters: \varnothing 6.5 mm \pm 0.1 mm Standard thickness: 0.50 mm \pm 0.1 mm
Field of View	min	Maximum angle of incidence shall be \pm 7° otherwise internal reflexions may modify the channel ratio!

InfraTec reserves the right to change these specifications at any time without notification.