

LRM-278-#

PYROMID® multi channel pyroelectric detector

Description: Engineering sample

eight channel; TO8 housing; small chip size; thermal compensation;
OpAmp; single supply; current mode; feedback 100 GOhm;
integrated temperature sensor;

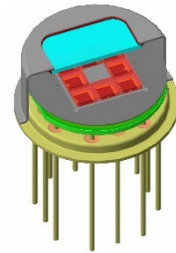

Housing:

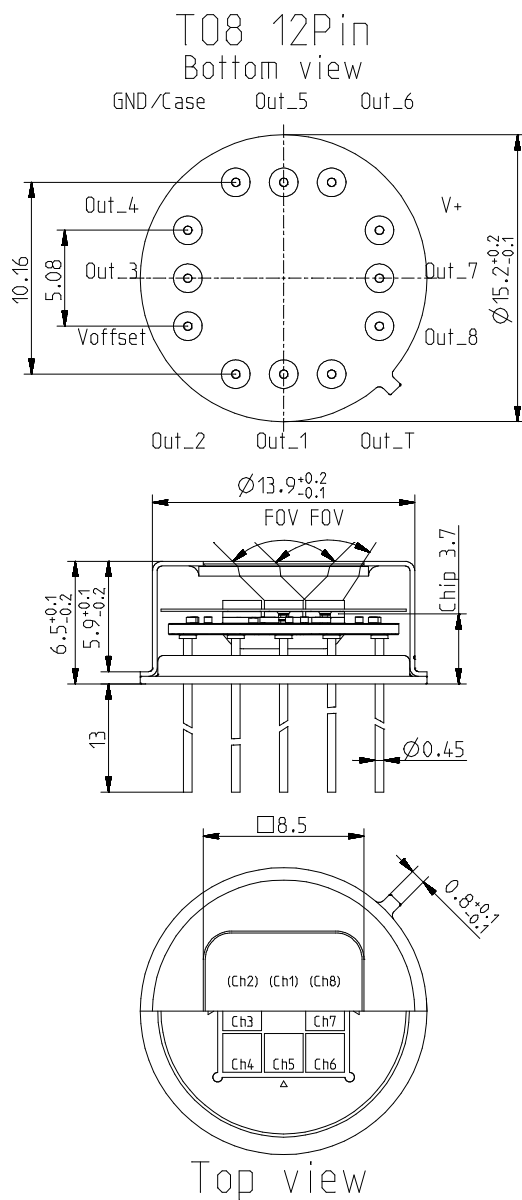

Pin Assignment:

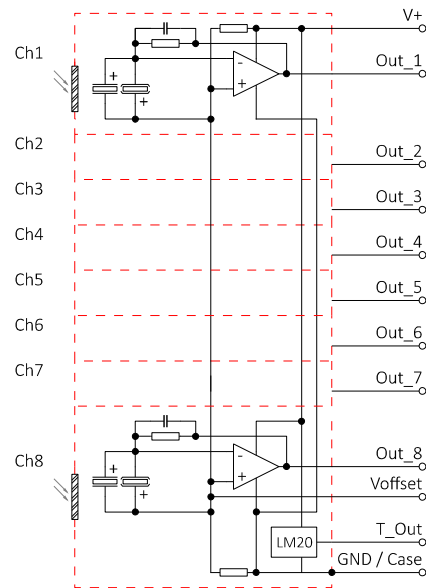

Frequency Response:

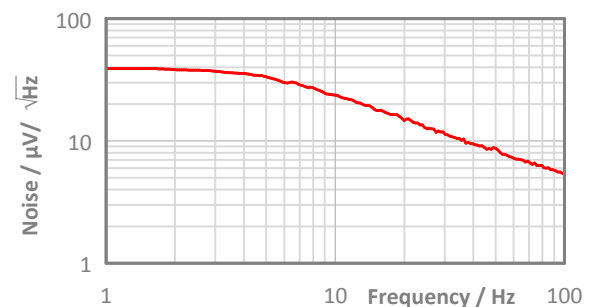
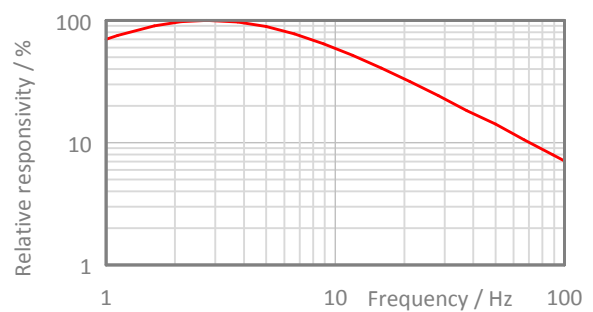

LRM-278-#

PYROMID® multi channel pyroelectric detector

Test Circuit:

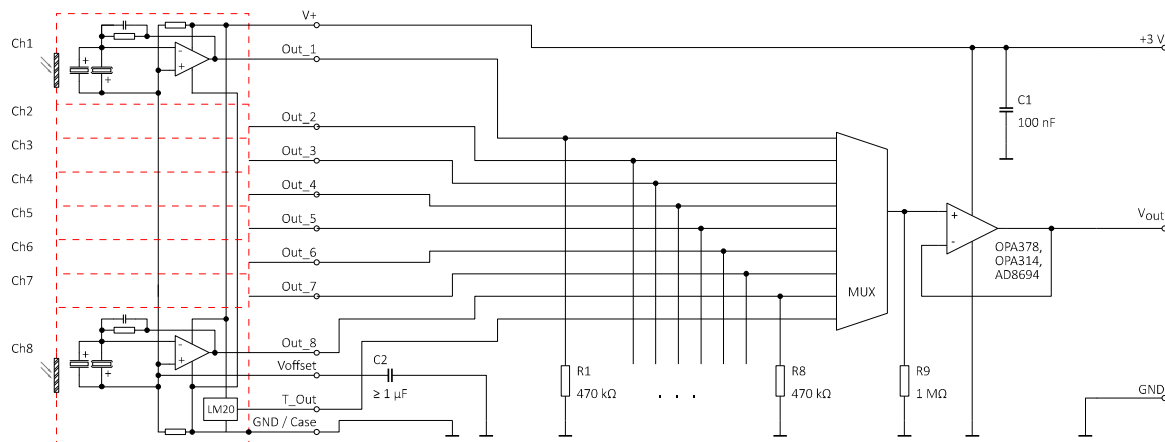

Parameters:

Aperture size	nom	□ 8.5 mm
Element size / type	nom	1.4 × 1.4 mm ² lithium-tantalate with black layer
Thermal time constant	typ	100 ms
Feedback resistor	nom	100 GΩ ±20 %
Feedback capacitor	nom	0.3 pF ±0.1 pF
Polarity	nom	Negative signal by positive IR flux change
Voltage responsivity (rms) {500 K, 10 Hz, 25 °C, without filter/window}	min	70,000 V/W
Noise density (rms) {10 Hz, BW 1 Hz, 25 °C}	max	45 μV/√Hz
Detectivity {500 K, 10 Hz, BW 1 Hz, 25 °C, without filter/window}	typ	4.5E+08 cmVHz/W
CMOS operational amplifier	nom	OpAmp4
Operating supply voltage V+		2.7 ... 5.0 V
Recommended supply voltage V+	nom	V+ = +3 V
Supply current {output load 1 MΩ}	max	1,800 μA
Offset voltage {25 °C; output load 1 MΩ}		V+/2 ±10%
internal Voffset (with load resistance > 1 MOhm)		V+/2 ±10%
recommended impedance for control of Voffset		10 kΩ
Optimal output load	nom	470 kΩ
Absolute output current	max	1 mA
Operating / Storage temperature	nom	-25 ... +85 °C
IR filter		Combinations of all InfraTec standard narrow band pass filters are available. Customized filters upon request.
Filter sizes	nom	Rectangular filters: (2.05 × 2.05) mm ±0.1 mm Circular filters: not applicable Standard thickness: 0.50 mm +0.2/-0.1 mm Thickness range 0.70 ... 1.10 mm on request
Aperture window		Selected by InfraTec for best channel filter matching
Aperture window sizes	nom	Rectangular filters: (9.00 × 9.00) mm ±0.05 mm Circular filters: not applicable Standard thickness: 0.50 mm ±0.1 mm
Field of View	min	70° (with filter: silicon substrate; 0.5 mm thick and aperture: Si ARC; 0.5 mm thick)

Engineering samples are manufactured for purposes of research and development. Characteristic values mentioned in the technical data sheet included are for guidance only and may not be used as guaranteed values.

InfraTec reserves the right to change these specifications at any time without notification.