

## LIE-216-#

## Single channel pyroelectric detector

### Description:

single channel; TO18 housing; small chip size; thermal compensation; JFET; voltage mode;

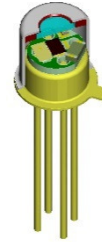

### Housing:

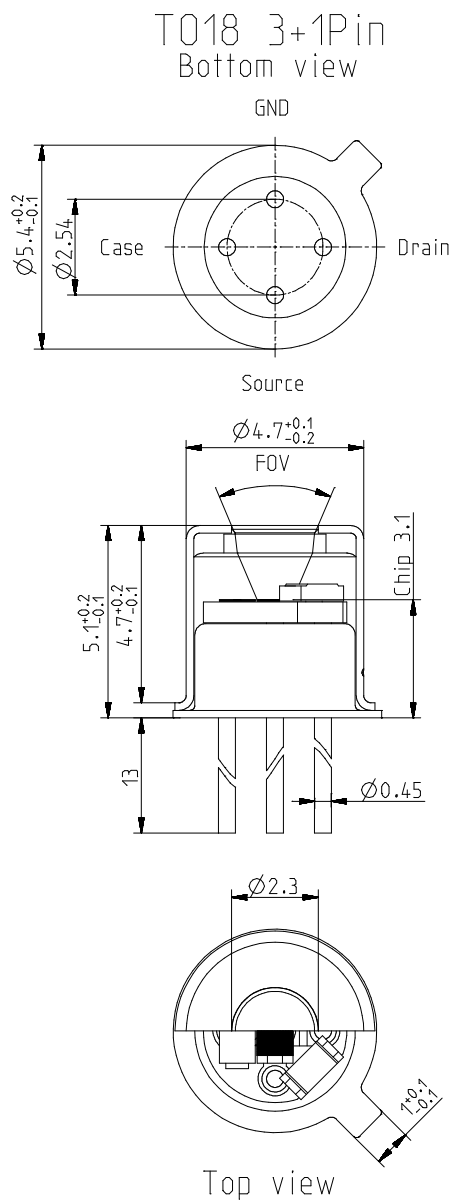

### Pin Assignment:

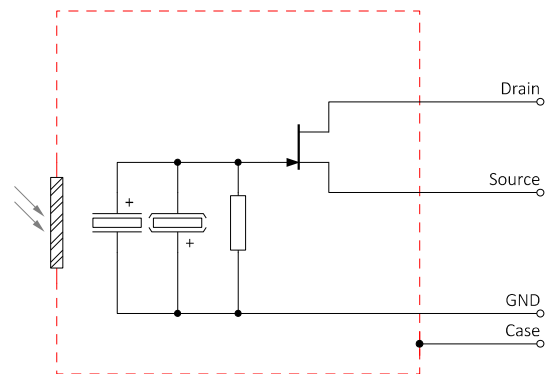

### Frequency Response:

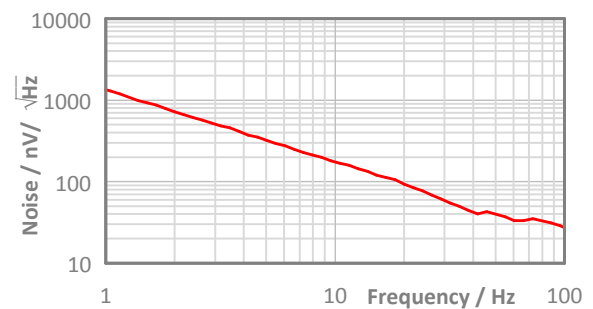
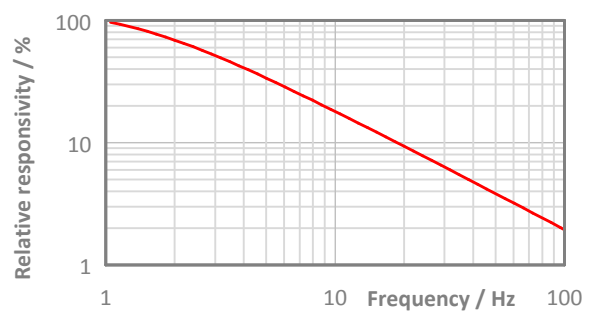

## LIE-216-#

## Single channel pyroelectric detector

### Test Circuit:

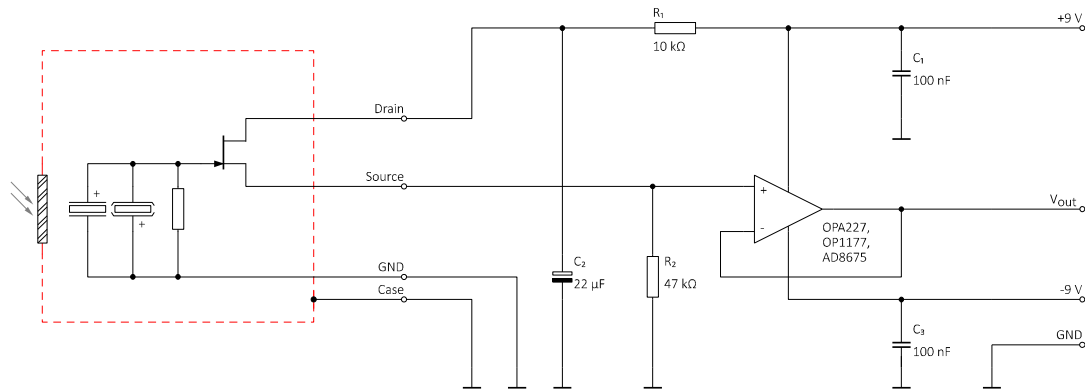

### Parameters:

Aperture size	nom	∅2.3 mm
Element size / type	nom	1.4 × 1.0 mm <sup>2</sup> lithium-tantalate with black layer
Thermal time constant	typ	150 ms
Electrical time constant	typ	4 s
Polarity	nom	Positive signal by positive IR flux change
Voltage responsivity (rms) {500 K, 10 Hz, 25 °C, without filter/window}	min	450 V/W
Noise density (rms) {10 Hz, BW 1 Hz, 25 °C}	max	220 nV/√Hz
Detectivity {500 K, 10 Hz, 1 Hz, 25 °C, without filter/window}	typ	3.0E+08 cmVHz/W
Offset voltage {opt. Drain current = 10 ... 100 μA}	nom	0.4 ... 1.5 V
Drain source voltage	max	18 V
Potential of detector case	nom	Selectable potential between -24 ... +24 V to Ground {EMC requires low-impedance coupling}
Operating / Storage temperature	nom	-40 ... +85 °C
IR filter		All InfraTec windows and filters are available (except KBr and CsI). Customized filters upon request.
Filter sizes	nom	Rectangular filters: (2.70 × 2.70) mm +0/-0.05 mm Circular filters: ∅3.3 mm ±0.1 mm Standard thickness: 0.50 mm +0.2/-0.1 mm Thickness range 0.70 ... 1.10 mm on request
Field of View	min	CaF <sub>2</sub> or BaF <sub>2</sub> ; 0.4 mm thick: 40° Silicon substrate; 0.5 mm thick: 45°

If visible light can penetrate the glass-metal seal in the detector socket, a small signal caused by light leakage may occur. InfraTec reserves the right to change these specifications at any time without notification.