

LME-352-#

Single channel pyroelectric detector

Description:

single channel; TO39 housing; medium chip size; low Micro;
OpAmp; ultra low power consumption; single supply; current mode; feedback 5 GOhm;

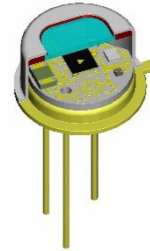

Housing:

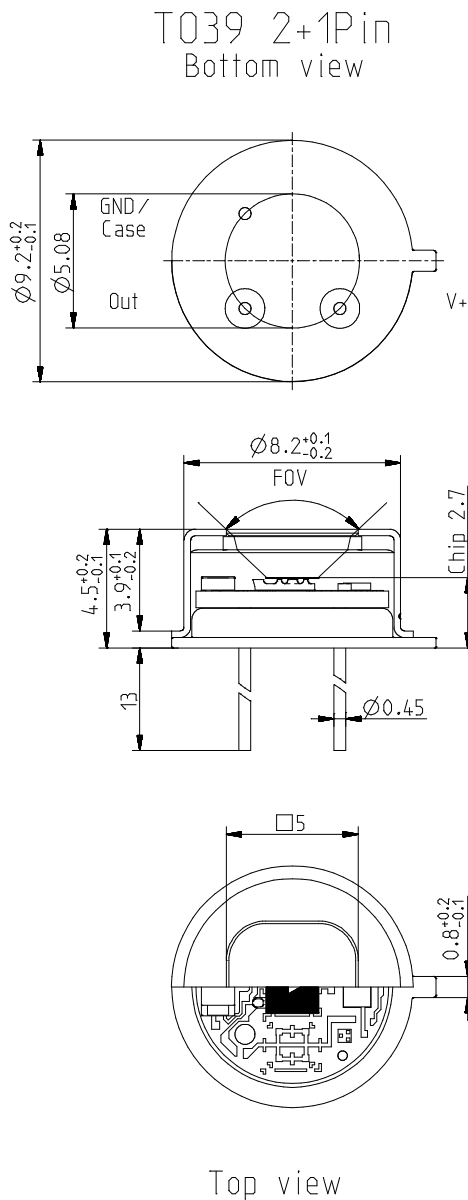

Pin Assigment:

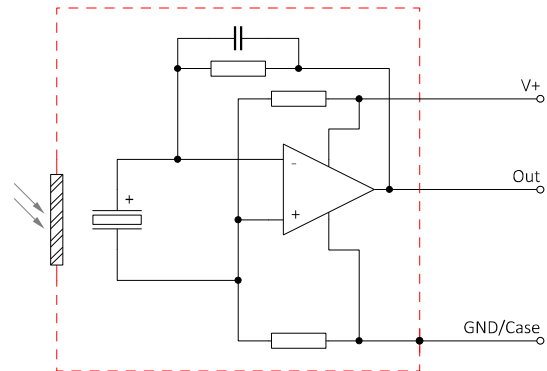

Frequency Response:

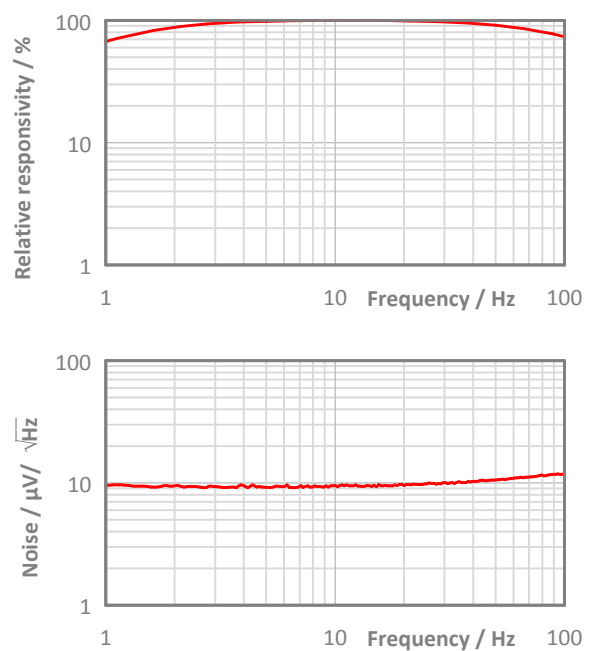

LME-352-#

Single channel pyroelectric detector

Test Circuit:

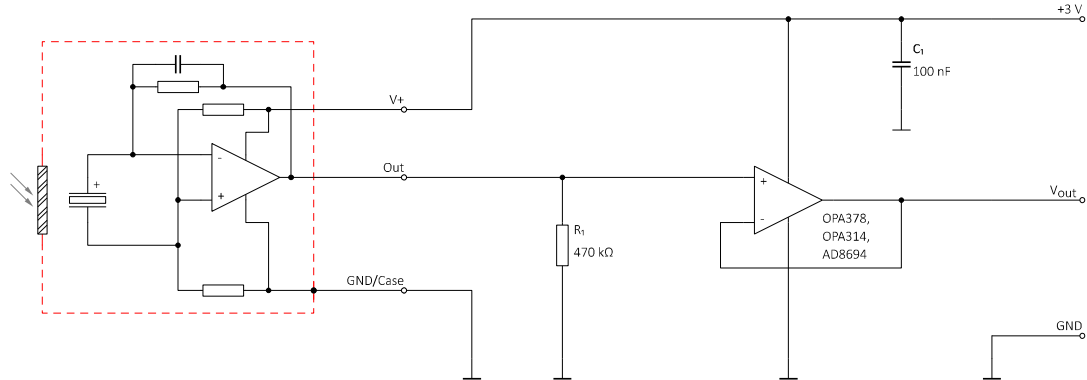

Parameters:

Aperture size	nom	□ 5.0 mm
Element size / type	nom	2.0 × 2.0 mm ² lithium-tantalate with black layer
Thermal time constant	typ	150 ms
Feedback resistor	nom	5 GΩ ±10 %
Feedback capacitor	nom	0.2 pF ±0.1 pF
Polarity	nom	Negative signal by positive IR flux change
Voltage responsivity (rms) {500 K, 10 Hz, 25 °C, without filter/window}	min	7,000 V/W
Noise density (rms) {10 Hz, BW 1 Hz, 25 °C}	max	12 μV/√Hz
Detectivity {500 K, 10 Hz, 1 Hz, 25 °C, without filter/window}	typ	1.5E+08 cmVHz/W
Acceleration response {5 ... 200 Hz}	typ	150 μV/g; g = 9.81 m/s ²
CMOS operational amplifier	nom	OpAmp3
Operating supply voltage V+		2.7 ... 10 V
Recommended supply voltage V+	nom	V+ = +3 V
Supply current {output load 1 MΩ}	max	45 μA
Offset voltage {25 °C; output load 1 MΩ}		V+/2 ±10%
Optimal output load	nom	470 kΩ
Absolute output current	max	1 mA
Operating / Storage temperature	nom	-40 ... +85 °C
IR filter		All InfraTec windows and filters are available (except KBr and CsI). Customized filters upon request.
Filter sizes	nom	Rectangular filters: (5.25 × 5.25) mm +0/-0.05 mm Circular filters: ø6.5 mm ±0.1 mm Standard thickness: 0.50 mm +0.2/-0.1 mm Thickness range 0.70 ... 1.10 mm on request
Field of View	min	CaF ₂ or BaF ₂ ; 0.4 mm thick: 80° Silicon substrate; 0.5 mm thick: 90°

InfraTec reserves the right to change these specifications at any time without notification.