

Test Data Sheet

PM9 - NIR

(EO-T2700M3-VIS)

S/N:

Resonant electro-optic phase modulator

with

- tunable resonance frequency
- temperature sensor (NTC)
- thermal crystal mount

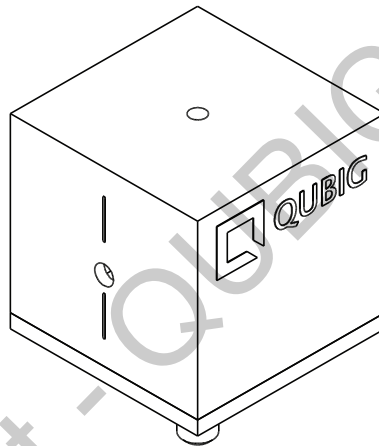

RF properties	Value	Unit
Resonance frequency: f_0 ¹⁾	2.38 - 2.78	GHz
Preset frequency: f_{set} ¹⁾	2726	MHz
Bandwidth: $\Delta\nu$	6.9	MHz
Quality factor: Q	395	
Required RF power for 1rad @ 780nm ²⁾	34.0	dBm
max. RF power (w/ active T-ctrl.): RF_{max} ³⁾	10	W

Optical properties		
EO crystal	MLN	
Aperture	3x3	mm ²
Wavefront distortion (633nm)	$\lambda/4$	nm
recommended max. optical intensity (780nm)	<10	W/mm ²
AR coating ($R_{avg} < 0.5\%$)	532 - 1064	nm

¹⁾ at 22.3°C ²⁾ with 50Ω termination ³⁾ w/o external active cooling

Fig. 1: Oscilloscope trace

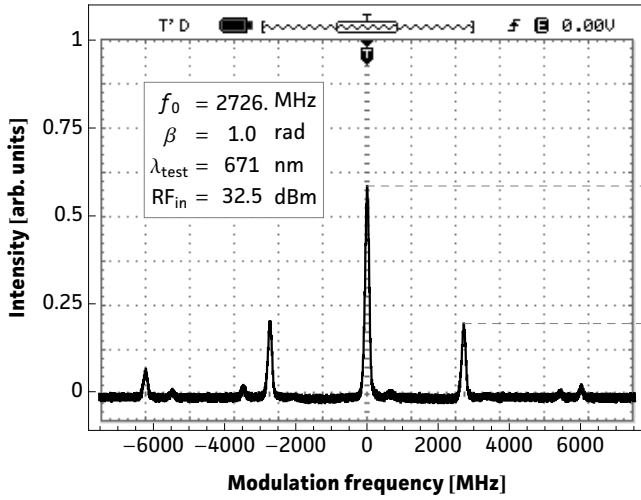

Fig. 2: Carrier/sideband ratio

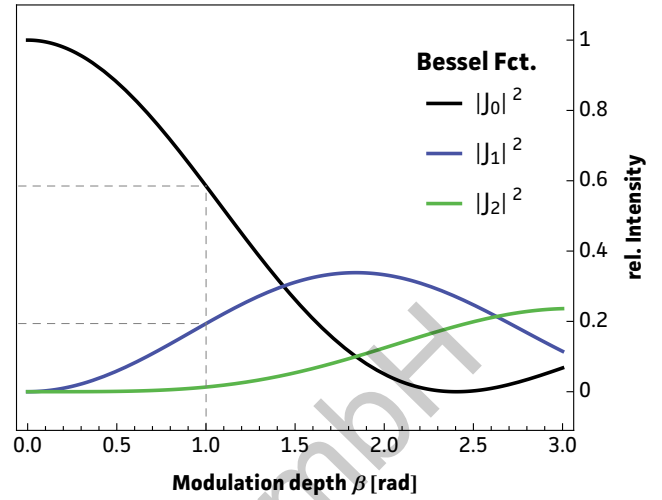

Table 1: Expected modulation

$\beta = 1 \text{ rad}$	unit	λ_1	λ_2
λ	nm	671	780
P	dBm	32.5	34.
P	W	1.78	2.51
U	V_p	13.3	15.8
U_π	V_p	41.9	49.8
β / U	rad / V	0.08	0.06

Fig.1: Recorded oscilloscope trace retrieved from a test setup as illustrated below.

Fig.2: Squared absolute values of first-kind Bessel functions vs. modulation depth. Vertical lines reveal the ratio between the carrier $|J_0|^2$ and the i^{th} sideband $|J_i|^2$ at a specific β .

Fig.3: Dependency between RF amplitude and modulation depth for different wavelengths. Points on the curve allow to retrieve either the required RF amplitude for a specific/desired β or the max. achievable modulation depth for a given/available RF power.

Table 1: Expected RF-amplitude/-power values and conversion factors for the required wavelength at the reference modulation depth of 1 rad. **Note:** Experimentally recorded modulation depth displayed in Fig.1 might vary from the respective values ($\beta=1\text{rad}$) provided in the table.

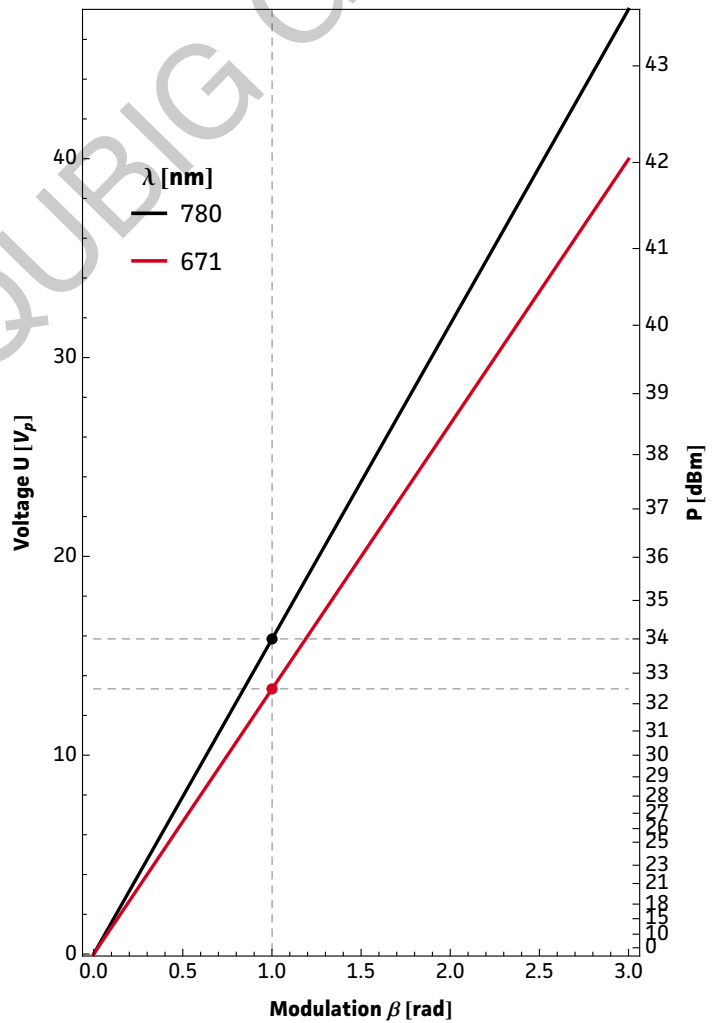
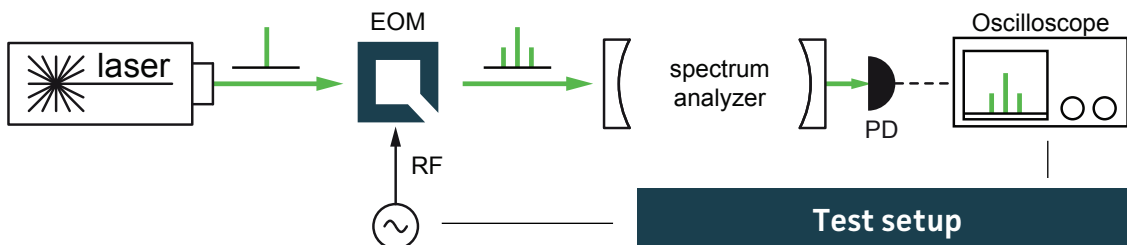
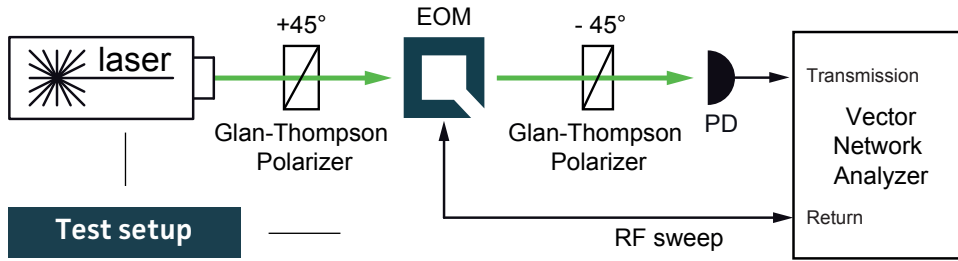

Fig. 3: RF-signal amplitude vs. modulation depth



Resonance characteristics



10/6/2016 10:58:19 AM
1328.5170K92-100178-XI

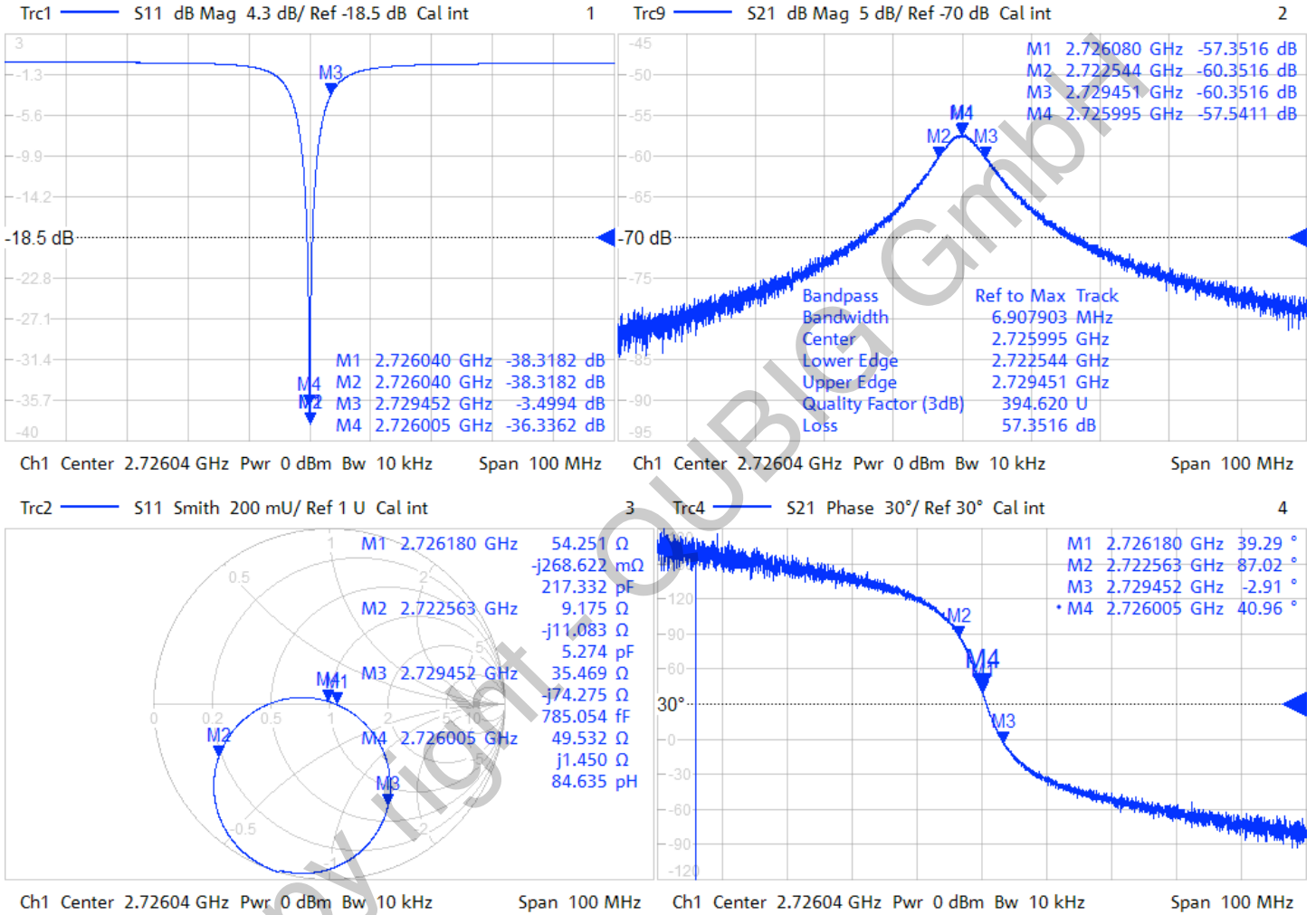

Tuning performance

MAX resonance frequency	$f_0 \text{ max}$	2778	MHz
MIN resonance frequency	$f_0 \text{ min}$	2383	MHz
number of turns	N_{max}	5	
counter clock-wise turns ↻	higher f_0 ↑		
clock-wise turns ↻	lower f_0 ↓		

- use only supplied tuning tool
- actuate tuner carefully
- do not apply too much pressure or torque
- keep tuning tool coaxial
- tuner might not be perfectly orthogonal to box

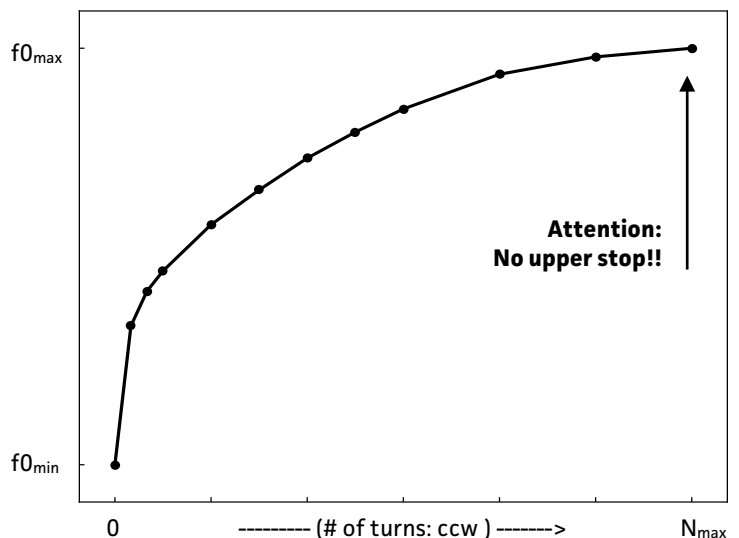

Handling instructions

- Input laser polarization must be aligned with respect to the white markers on the housing
- Please handle device carefully. Avoid shock. Don't drop.
- After turn on the resonance frequency might drift slightly with applied RF power. Please compensate by tuning the RF drive frequency until steady-state (~min).

Package drawing

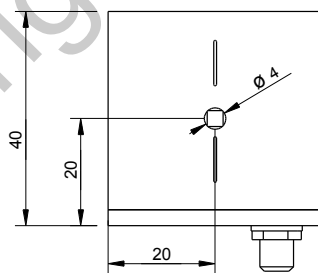
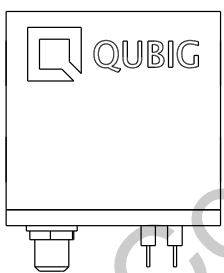
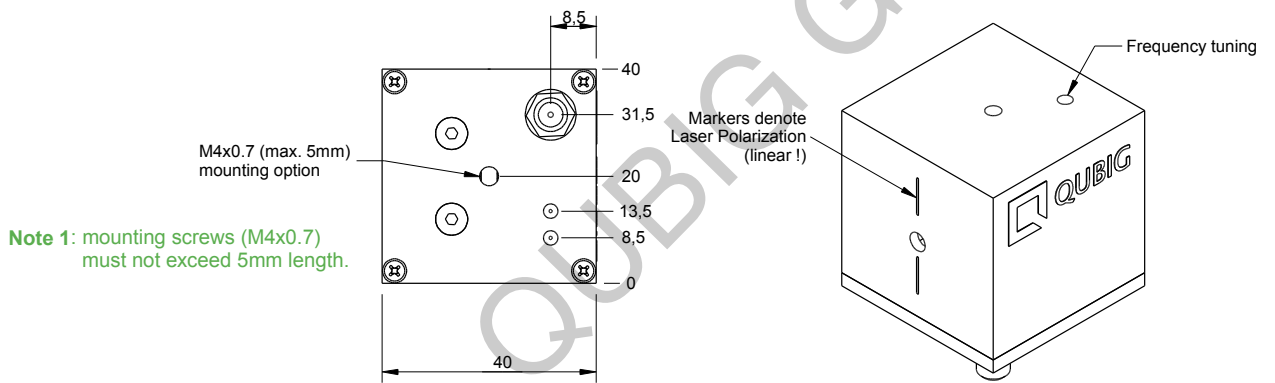

Note 2: crystal aperture is 3x3mm.

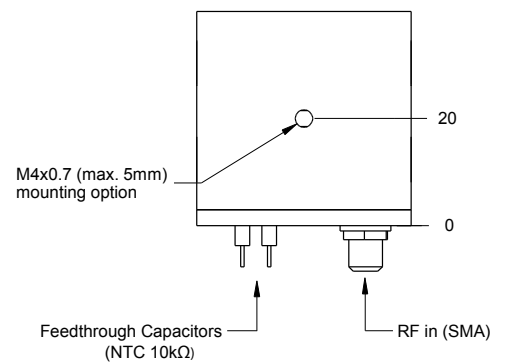

use this side for heat sinking

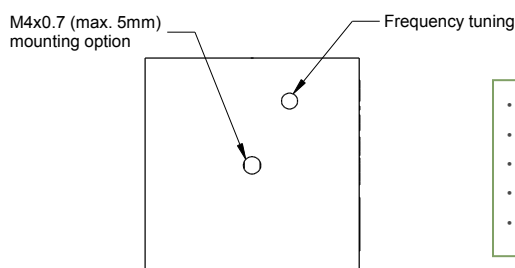
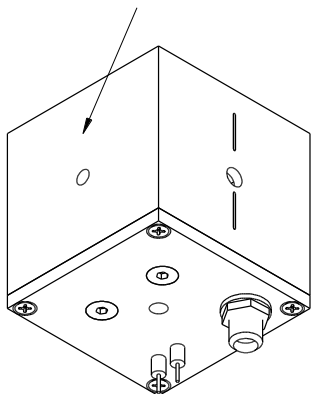

Attention!!

- use only supplied tuning tool
- actuate tuner carefully
- do not apply too much pressure or torque
- keep tuning tool coaxial
- tuner might not be perfectly orthogonal to box

TXC-option information

Delivery contents:

- TEC for active T-ctrl. (additional T-controller required)
- SMD capacitor: 1x 47uF - C1210C476M4PACTU
- Thermally insulating screw: M4, 1pc.
- Thermal pads: 2x, double sided adhesive (50x50mm²)

NTC characteristics

NTC part number	Resistance (25°C) (ohm)	B-Constant (25-50°C) (K)	Operating Current for Sensor (25°C) (mA)	Rated Electric Power (25°C) (mW)	Typical Dissipation Constant (25°C) (mW/°C)	Thermal Time Constant (25°C) (s)
NXFT15XH103FA2B050	10k +/- 1%	3380 +/- 1%	0.12	7.5	1.5	4

- Operating Current for Sensor rises Thermistor's temperature by 0.1°C
- Rated Electric Power shows the required electric power that causes Thermistor's temperature to rise to 30°C by self heating, at ambient temperature of 25°C.

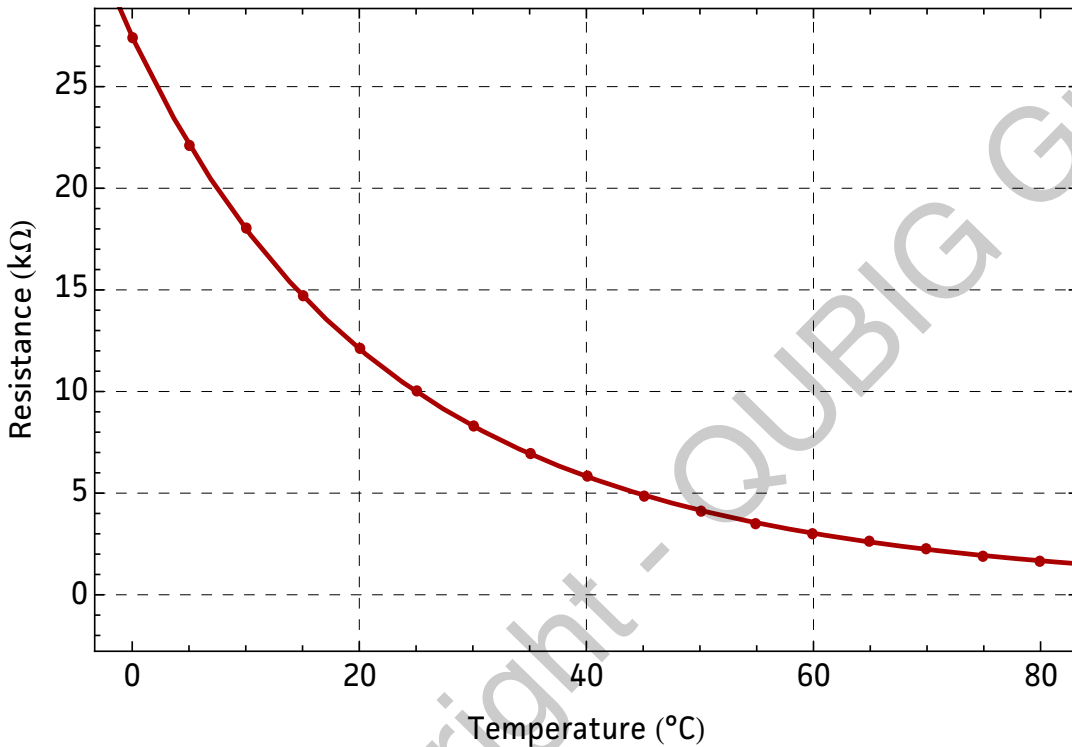

Part Number	NXFT15XH103
Resistance	10kΩ
B-Constant	3380K
Temp. (°C)	Resistance (kΩ)
-40	197.388
-35	149.395
-30	114.345
-25	88.381
-20	68.915
-15	54.166
-10	42.889
-5	34.196
0	27.445
5	22.165
10	18.010
15	14.720
20	12.099
25	10.000
30	8.309
35	6.939
40	5.824
45	4.911
50	4.160
55	3.539
60	3.024
65	2.593
70	2.233
75	1.929
80	1.673
85	1.455
90	1.270
95	1.112
100	0.976
105	0.860
110	0.759
115	0.673
120	0.598
125	0.532

TEC characteristics

TEC part number	I _{max} (A)	U _{max} (V)	Q _{cmax} (W)	ΔT _{max} (K)	T _{max} (°C)	A (mm)	B (mm)	H (mm)	ID (mm)	Sealing
UEPT-440-127-040M125S	4.0	15.2	40	67.0	125.0	40.0	40.0	4.6	4.5	Silicon

