



Test Data Sheet

PM9 - UV

(old: EO-T1250P3-UV)

S/N:

Resonant electro-optic phase modulator

with

- temperature control option
- hermetically sealed housing
- tunable resonance frequency

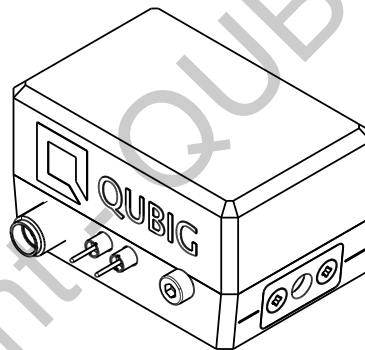

RF properties	Value	Unit
Resonance frequency: f_0 ¹⁾	1.1 - 1.29	GHz
Preset frequency: f_{set} ¹⁾	1250	MHz
Bandwidth: $\Delta\nu$	3.8	MHz
Quality factor: Q	325	
Required RF power for 1rad @ 313nm ²⁾	35.7	dBm
max. RF power: RF_{max} ³⁾	2	W

Optical properties		
EO crystal	KDP	
Aperture	3x3	mm ²
Wavefront distortion (633nm)	$\lambda/8$	nm
recommended max. optical intensity (280nm)	<1	W/mm ²
AR coating (R<0.5%)	200-400	nm

¹⁾ at 25°C ²⁾ with 50Ω termination ³⁾ no damage with $RF_{in} < 5W$

Measured modulation

Fig. 1: Oscilloscope trace

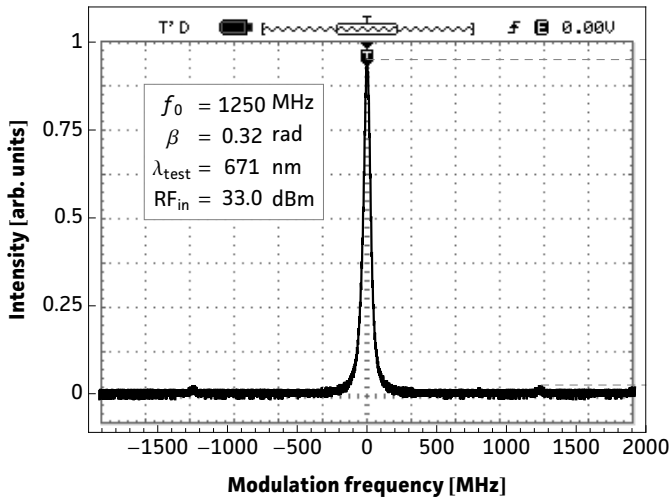

Fig. 2: Carrier/sideband ratio

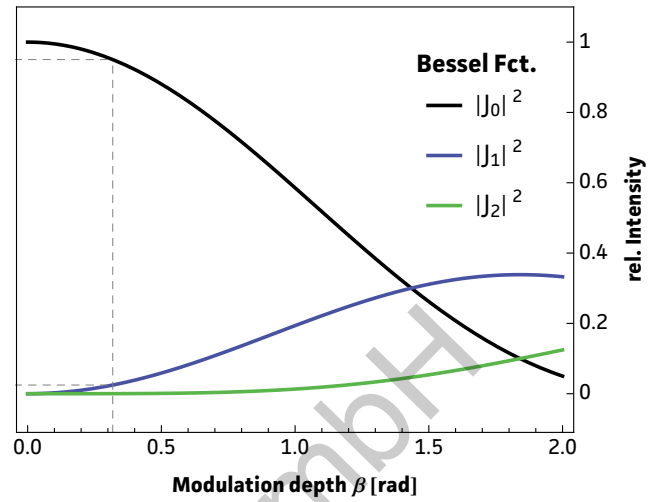

Table 1: Expected modulation

$\beta = 1 \text{ rad}$	unit	λ_1	λ_2
λ	nm	313	671
P	dBm	35.7	42.9
P	W	3.73	19.71
U	V _p	19.3	44.4
U_π	V _p	60.7	139.5
β / U	rad / V	0.05	0.02

Fig.1: Recorded oscilloscope trace retrieved from a test setup as illustrated below.

Fig.2: Squared absolute values of first-kind Bessel functions vs. modulation depth. Vertical lines reveal the ratio between the carrier $|J_0|^2$ and the i^{th} sideband $|J_i|^2$ at a specific β .

Fig.3: Dependency between RF amplitude and modulation depth for different wavelengths. Points on the curve allow to retrieve either the required RF amplitude for a specific/desired β or the max. achievable modulation depth for a given/available RF power.

Table 1: Expected RF-amplitude/-power values and conversion factors for the required wavelength at the reference modulation depth of 1 rad. **Note:** Experimentally recorded modulation depth displayed in Fig.1 might vary from the respective values ($\beta=1\text{rad}$) provided in the table.

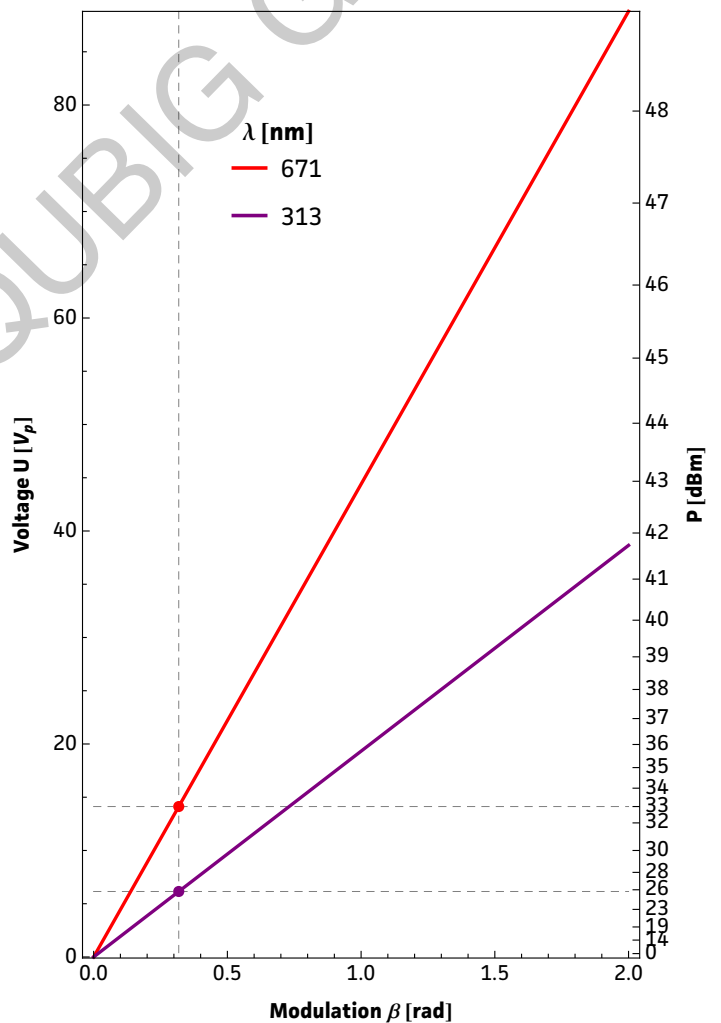
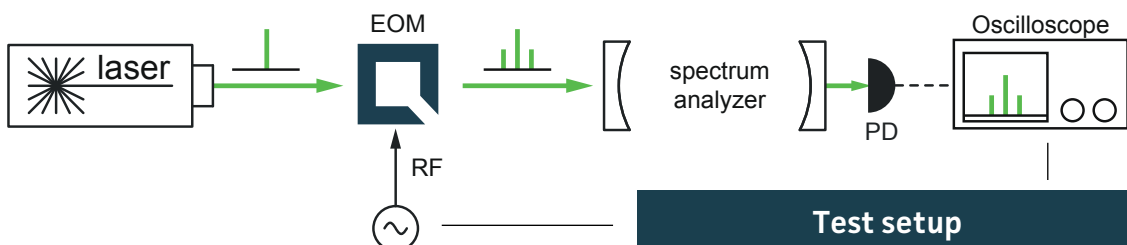
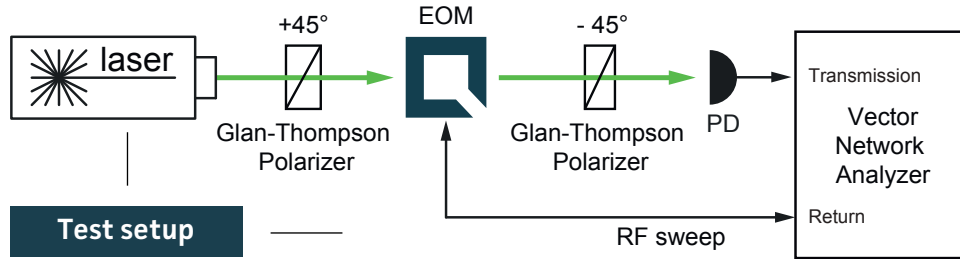

Fig. 3: RF-signal amplitude vs. modulation depth



Resonance characteristics



4/26/2018 11:04:03 AM
1328.5170K92-100178-XI

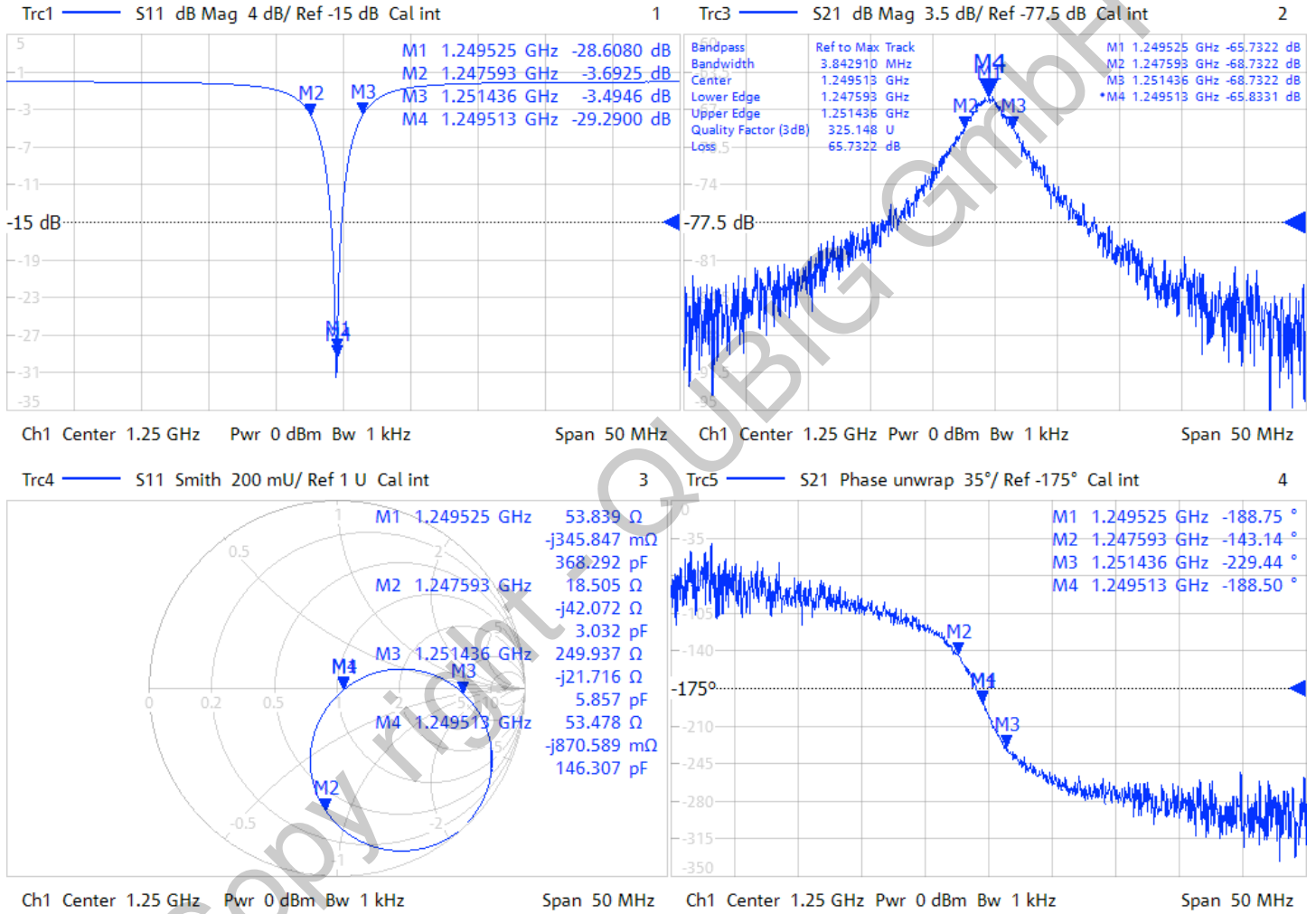

Tuning performance

MAX resonance frequency	f_0 max	1292	MHz
MIN resonance frequency	f_0 min	1105	MHz
number of turns	N_{max}	5	
counter clock-wise turns ↻	higher f_0 ↑		
clock-wise turns ↻	lower f_0 ↓		

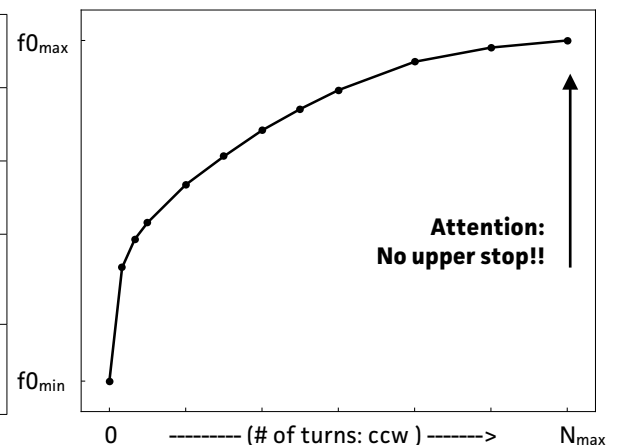

Operation / handling instructions

The resonance frequency and the modulation strength of the EOM are temperature dependent. In order to achieve a modulation depth of ~1rad at 313nm about 4W RF power is required, which leads to a temperature increase and hence a frequency shift of up to 5-10MHz (w/o active cooling). In order to reach a thermal equilibrium, Qubig recommends the following procedure:

1. Put the EOM together with the TEC in between on a properly dimensioned heatsink.
 2. Attach the NTC of the EOM housing to your temperature controller.
 3. Activate the T-control and cool the EOM down to about 5°C above the dew point. **AVOID condensation!**
 4. Turn on your RF source at a low output level (20dBm).
 5. Locate the resonance frequency by maximizing your signal of interest (e.g. sidebands, error signal)
 6. Gradually increase the RF power and adjust the modulation frequency simultaneously by keeping your signal of interest maximized.
 7. Once the desired modulation depth is reached, either carefully use the provided tuning tool (coarse adjustment) or change the Temperature (fine adjustment) of the EOM to finally set the required frequency.
 8. In thermal equilibrium the EOM is in a fragile state and needs to be protected from external disturbances (temperature fluctuations).
- Please handle device carefully. Avoid shock. Don't drop.

Package drawing

Attention!!!

Housing is hermetically sealed.
No use serviceable parts inside.
Screws must not be loosened!
Crystal will be damaged otherwise.

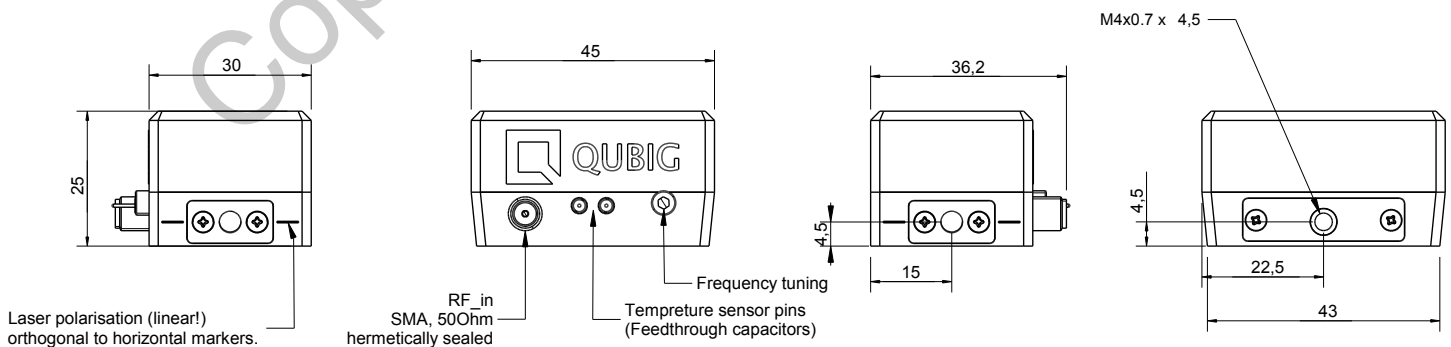
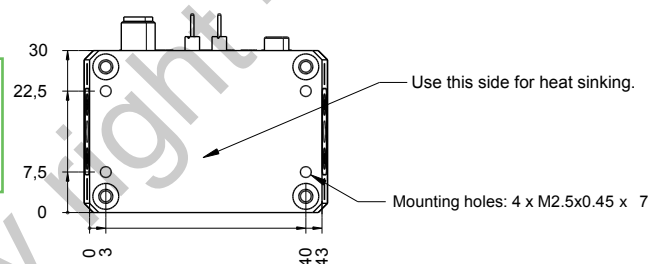

Attention:

M2.5 screw on rubber socket protects the inside from humidity. To adjust the resonance frequency remove the screw and use the provided tuning tool. After the adjustments don't forget to seal the housing again. The crystal will get damaged otherwise.

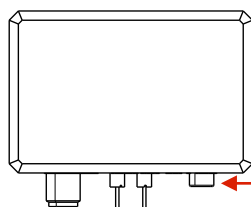
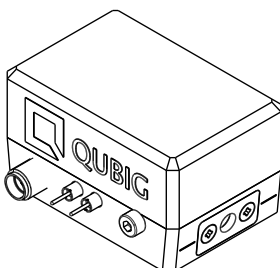

TXC-option information

NTC characteristics:

NTC part number	Resistance (25°C) (ohm)	B-Constant (25-50°C) (K)	Operating Current for Sensor (25°C) (mA)	Rated Electric Power (25°C) (mW)	Typical Dissipation Constant (25°C) (mW/°C)	Thermal Time Constant (25°C) (s)
NXFT15XH103FA2B050	10k +/- 1%	3380 +/- 1%	0.12	7.5	1.5	4

- Operating Current for Sensor rises Thermistor's temperature by 0.1°C
- Rated Electric Power shows the required electric power that causes Thermistors's temperature to rise to 30°C by self heating, at ambient temperature of 25°C.

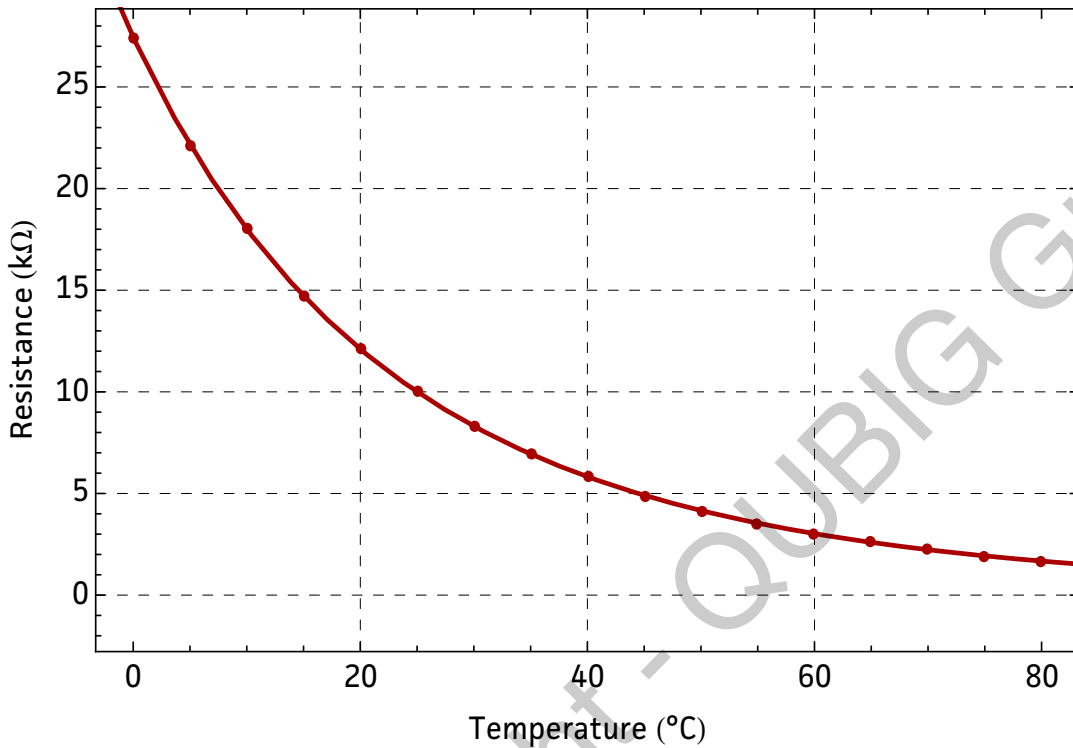

Part Number	NXFT15XH103
Resistance	10kΩ
B-Constant	3380K
Temp. (°C)	Resistance (kΩ)
-40	197.388
-35	149.395
-30	114.345
-25	88.381
-20	68.915
-15	54.166
-10	42.889
-5	34.196
0	27.445
5	22.165
10	18.010
15	14.720
20	12.099
25	10.000
30	8.309
35	6.939
40	5.824
45	4.911
50	4.160
55	3.539
60	3.024
65	2.593
70	2.233
75	1.929
80	1.673
85	1.455
90	1.270
95	1.112
100	0.976
105	0.860
110	0.759
115	0.673
120	0.598
125	0.532

TEC characteristics:

TEC part number	I _{max} (A)	U _{max} (V)	Q _{cmax} (W)	ΔT _{max} (K)	T _{max} (°C)	A (mm)	B (mm)	H (mm)	ID (mm)	Sealing
UEPT-130-127-040M125	4.0	15.2	37.7	66	125	30.0	30.0	3.1	w/o	Silicon

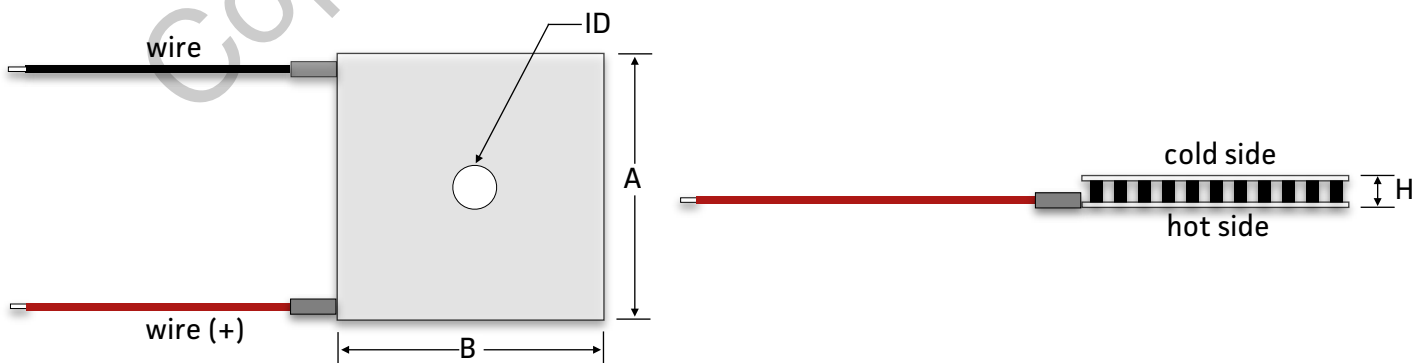

Tested by: