

Test Data Sheet

PM9 - VIS
 (EO-T1650M3-VIS)
 S/N:

Resonant electro-optic phase modulator
 with
 - tunable resonance frequency
 - thermal crystal mount

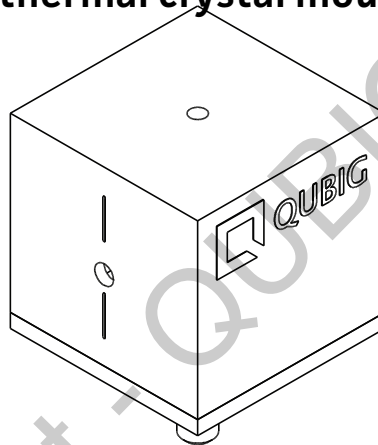

RF properties	Value	Unit
Resonance frequency: f_0 ¹⁾	1.52 - 1.74	GHz
Preset frequency: f_{set} ¹⁾	1650	MHz
Bandwidth: $\Delta\nu$	5.5	MHz
Quality factor: Q	300	
Required RF power for 1rad @ 640nm ²⁾	28.2	dBm
max. RF power: RF_{max} ³⁾	2	W

Optical properties		
EO crystal	MLN	
Aperture	3x3	mm ²
Wavefront distortion (633nm)	$\lambda/4$	nm
recommended max. optical intensity (369nm)	<1	W/mm ²
AR coating ($R_{avg} < 0.5\%$)	370 - 800	nm

¹⁾ at 22.3°C ²⁾ with 50Ω termination ³⁾ no damage with $RF_{in} < 5W$

Measured modulation

Fig. 1: Oscilloscope trace

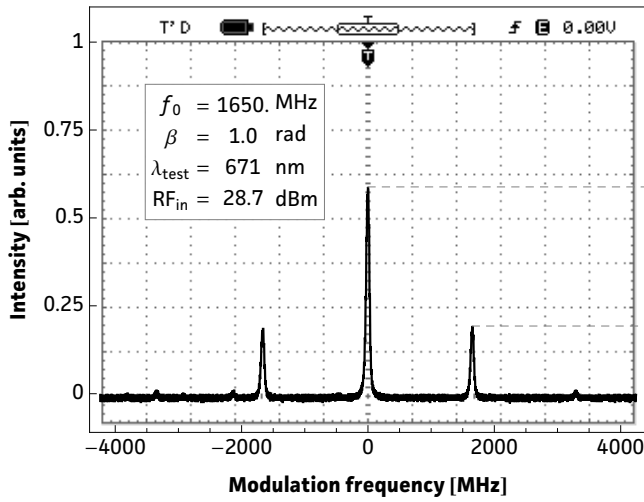

Fig. 2: Carrier/sideband ratio

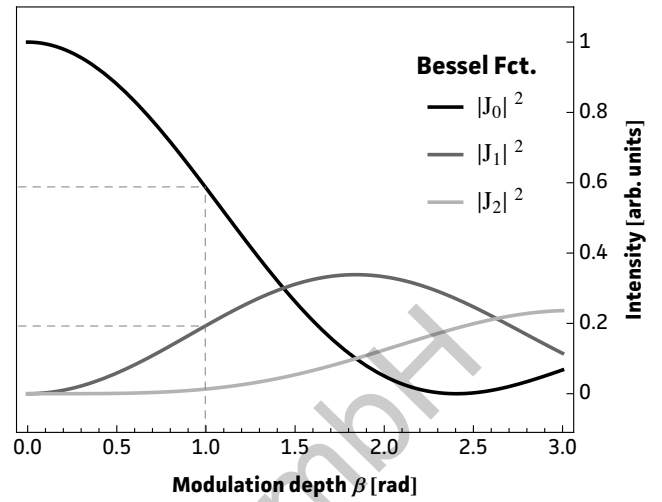

Table 1: Expected modulation

$\beta = 1$ rad	unit	λ_1	λ_2
λ	nm	640	671
P	dBm	28.2	28.7
P	mW	667	746
U	V _p	8.2	8.6
U _{π}	V _p	25.7	27.2
β / U	rad / V	0.12	0.12

Fig.1: Recorded oscilloscope trace retrieved from a test setup as illustrated below.

Fig.2: Squared absolute values of first-kind Bessel functions vs. modulation depth. Vertical lines reveal the ratio between the carrier $|J_0|^2$ and the i^{th} sideband $|J_i|^2$ at a specific β .

Fig.3: Dependency between RF amplitude and modulation depth for different wavelengths. Points on the curve allow to retrieve either the required RF amplitude for a specific/desired β or the max. achievable modulation depth for a given/available RF power.

Table 1: Expected RF-amplitude/-power values and conversion factors for the required wavelength at the reference modulation depth of 1 rad. **Note:** Experimentally recorded modulation depth displayed in Fig.1 might vary from the respective values ($\beta=1$ rad) provided in the table.

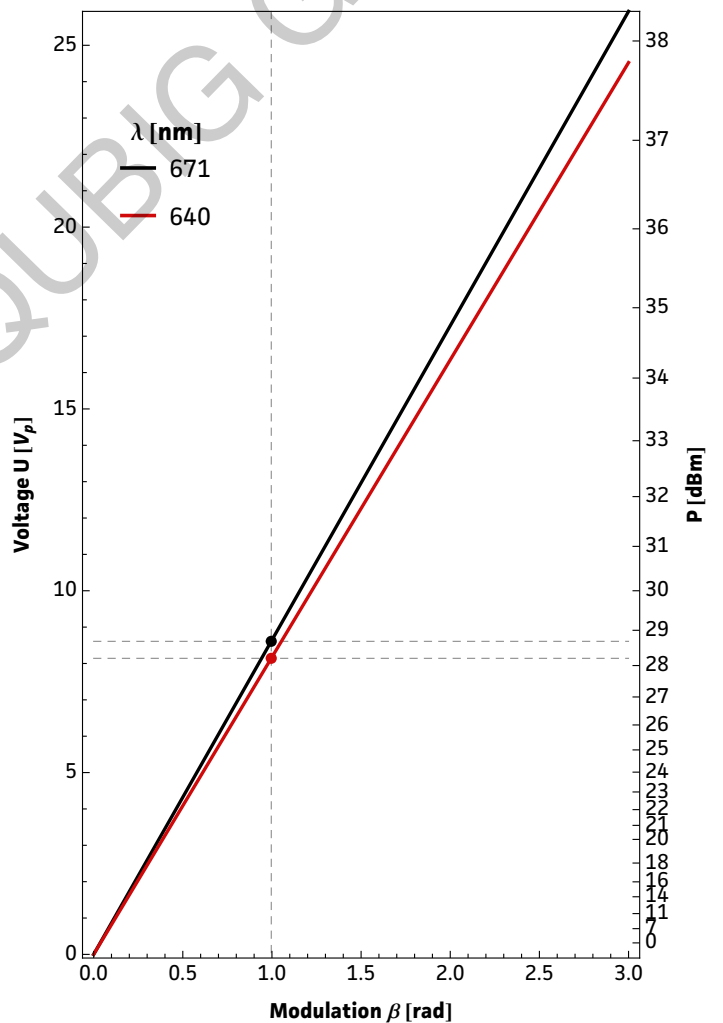
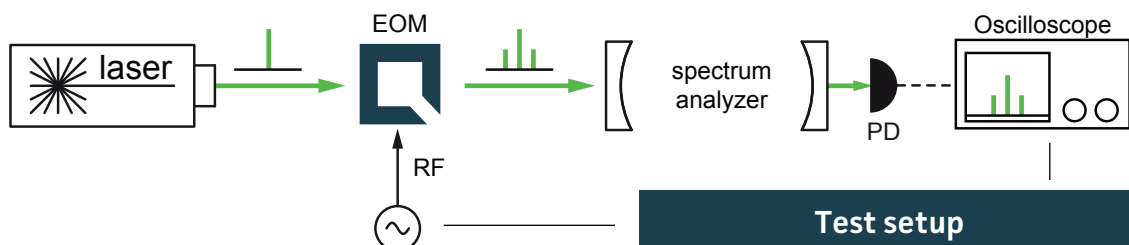
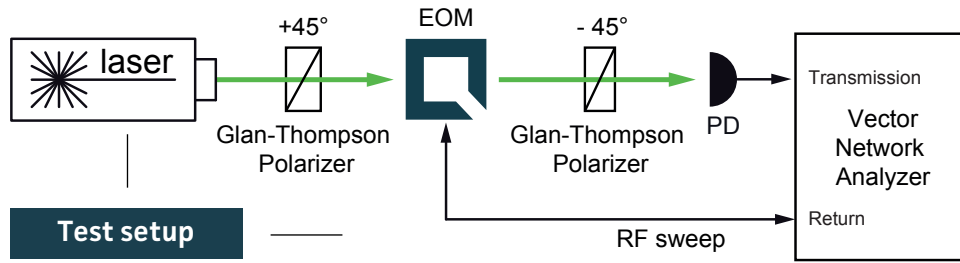

Fig. 3: RF-signal amplitude vs. modulation depth



Resonance characteristics



1/28/2017 5:56:36 PM
1328.5170K92-100178-XI

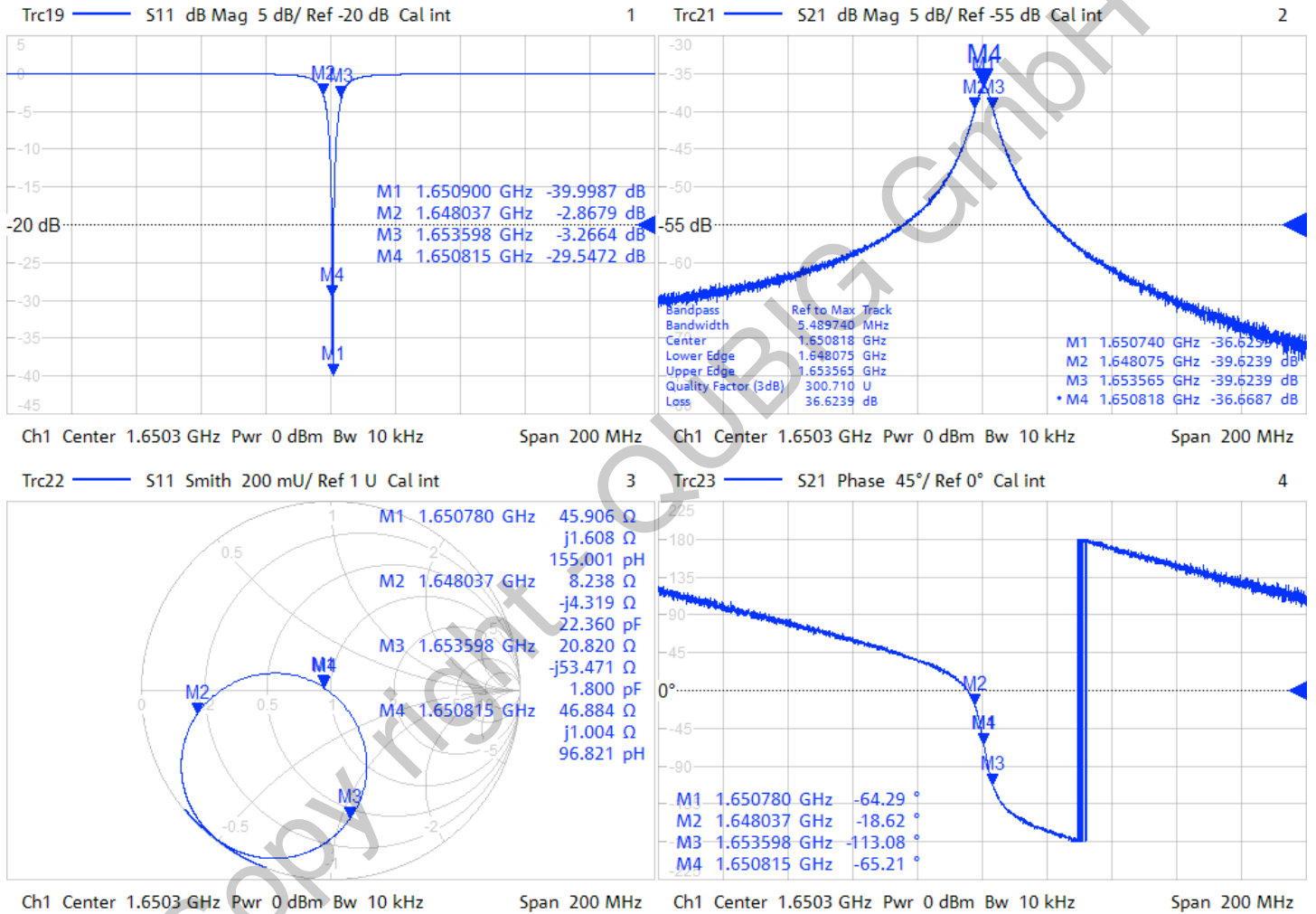

Tuning performance

MAX resonance frequency	$f_0 \text{ max}$	1.74	MHz
MIN resonance frequency	$f_0 \text{ min}$	1.52	MHz
number of turns	N_{max}	5	
counter clock-wise turns ↻			↑
clock-wise turns ↻			↓

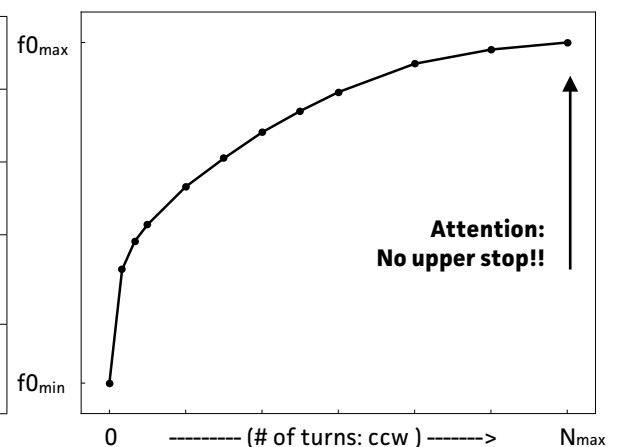

Handling instructions

- Input laser polarization must be aligned with respect to the white markers on the housing
- Please handle device carefully. Avoid shock. Don't drop.
- After turn on the resonance frequency might drift slightly with applied RF power. Please compensate by tuning the RF drive frequency until steady-state (~min).

Package drawing

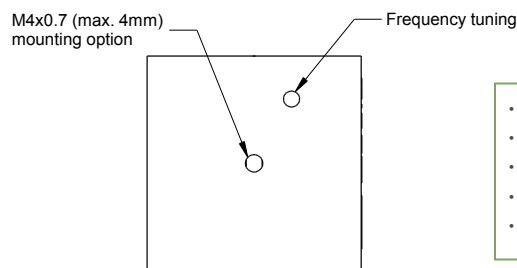
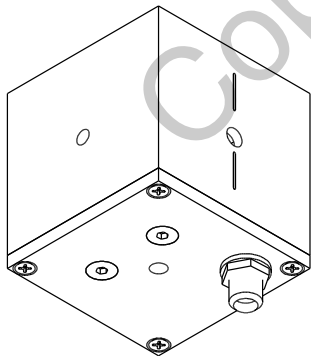
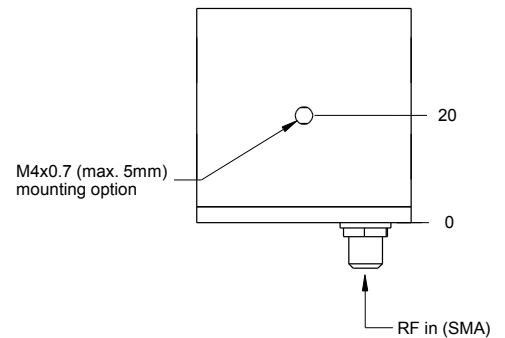
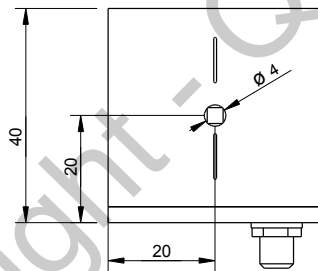
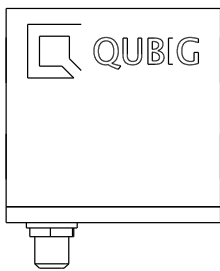
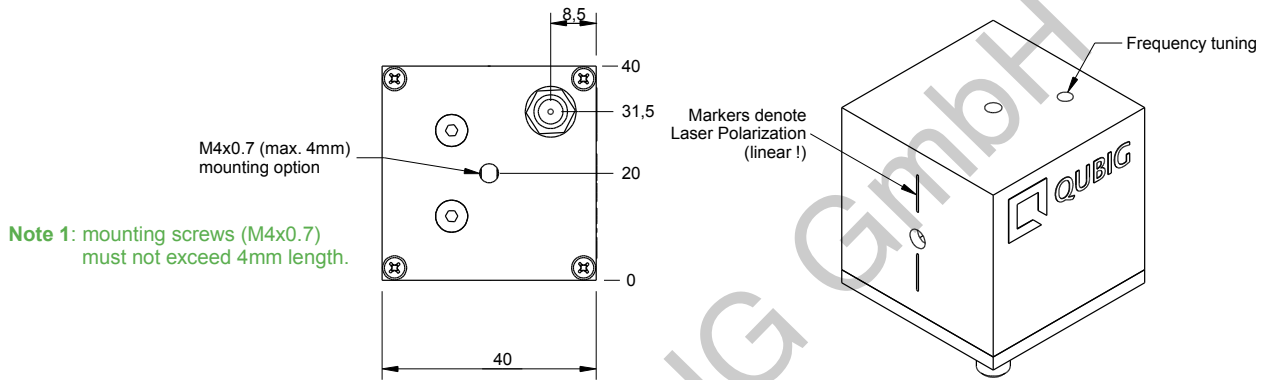

Attention!!

- use only supplied tuning tool
- actuate tuner carefully
- do not apply too much pressure or torque
- keep tuning tool coaxial
- tuner might not be perfectly orthogonal to box

Tested by:
